

PPT20

PPT20 is the ideal choice for material transportation in medium or long distance, (optional foldable platform), suitable for most applications. The high power vertical AC drive system ensures the high performance of the truck.



ADVANTAGES

- Robust and ergonomic design.
- AC drive system provides sufficient power.
- Steel battery cover and drive frame housing.
- Suitable for indoor heavy-duty applications in a long work cycle.
- American Curtis controller.
- 1.3KW high power vertical drive.

MALAYSIA

KL (HQ): Tel: (6)03-3392 3813 (HL) Fax: (6)03-3392 1344
PENANG: Tel: (6)04-333 3160 (HL) Fax: (6)04-333 3172
JOHOR: Tel: (6)07-355 0030 (HL) Fax: (6)07-355 0085

INDONESIA

JAKARTA: Tel: (62)021 5596 1191 Fax: (62)021 5596 1195
SURABAYA: Tel: (62)031 9971 3154 Fax: (62)031 9971 2655

THAILAND

SAMUTPRAKARN: Tel: (66) 02-174 7040 (HL) Fax: (66) 02-174 7043
AYUTTHAYA: Tel: (66) 03-533 5696 (HL) Fax: (66) 03-533 5699
CHONBURI: Tel: (66) 8-3115 2002

PHILIPPINES

MANILA: Tel: (63) 91-7158 5820 Fax: (63) 46 538 9971

SUPERFORM[®]
Material Handling



PPT20

Powered pallet truck
Ideal choice for most material handling applications

Rated Capacity
2000Kg



Easy
Maintenance



High
Performance



High Capacity
Battery



Robust and
Reliable Design

NEW *Superform Products*
ARRIVAL

BAN NGAI GROUP

www.banngai.com

Ergonomic designed Intelligent tiller head

Comfortable operation, optimize operator's comfort. All the switch buttons are integrated in the humanized touch position for easy operation. (Integrated pin code, hour meter, battery discharge indicator, fault code display, turtle speed)



High power vertical drive

The high power vertical AC drive system ensures the high performance of the truck. High capacity, Small turning radius, Excellent heat dissipation, Long service life and easy maintenance.

Vertical drive

1.3KW high power vertical drive, with the rotating support can be equipped with AC or DC motors, is suitable for heavy-duty applications in long work cycle.



Mature design



Easy pallet entry

Additional entry rollers ensure easy pallet entry and prevent possible damages.



Controller

American Curtis controller, which provides extremely reliable and flexible solutions with high performance level of the control system.



Robust design

Strong metal battery cover and drive frame housing. The strong battery cover made out of steel helps to provide a high level of strength for this part.



Optional ergonomic tiller head

Ergonomic handle, easy to use on both sides. The turtle speed switch ensures safer operation in narrow spaces.



Optional control element

Key switch, emergency stop switch and electricity meter.



Foldable platform

Optional foldable platform and side guard rail. The ergonomically designed foldable platform in combination with its sideways protective arms makes operations faster and safer.



Optional American parts

Optional typical American frame with short fork tip.

Other optional

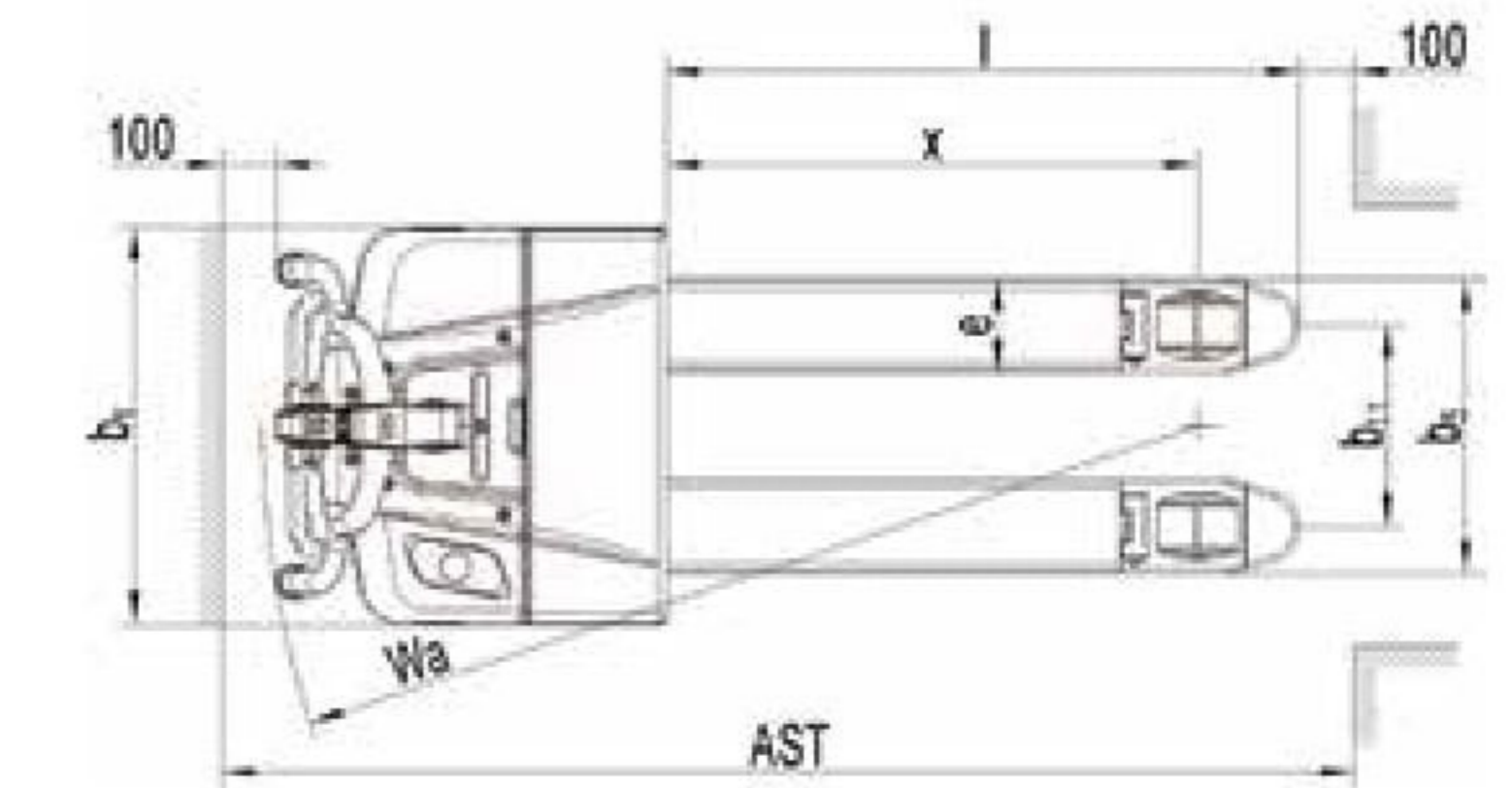
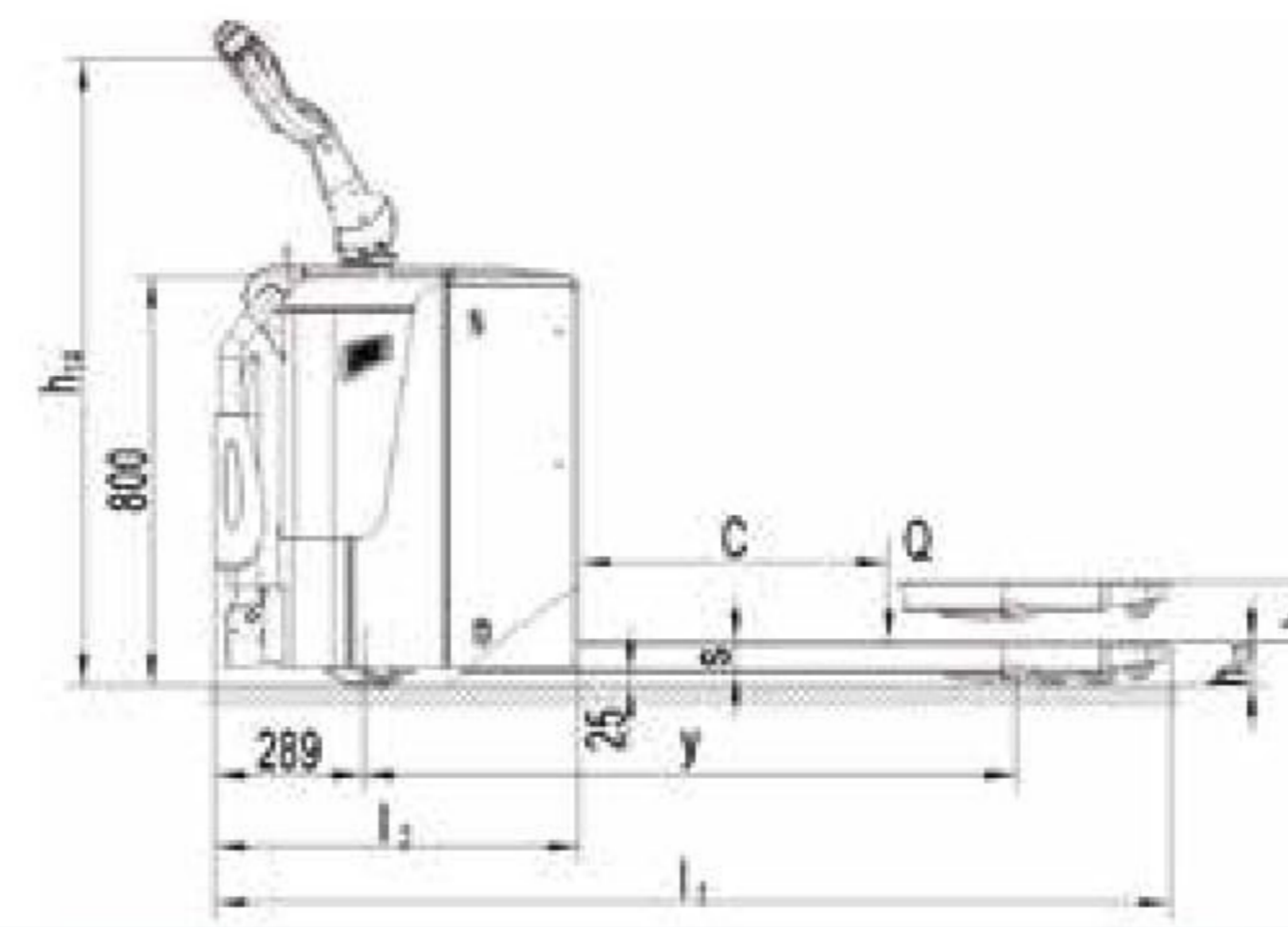

Type sheet for industrial truck acc. to VDI2198

Type sheet for industrial truck acc. to VDI2198			
Distinguishing mark			
1.2	Model No.		PPT20
1.3	Drive		Battery
1.4	Operator type		Foldable platform
1.5	Load capacity/Rated load	Q (t)	2.0
1.6	Load centre distance	c (mm)	600
1.8	Load distance,centre of drive axle to fork	x (mm)	965
1.9	Wheelbase	y (mm)	1388
Weight			
2.1	Service weight	kg	634 (With Foldable platformand guard rail)
2.2	Axle loading, laden front/rear	kg	960 / 1674
2.3	Axle loading,unladen front/rear	kg	514 / 120
Tyres,chassis			
3.1	Tyre		Polyurethane(PU)
3.2	Tyre size,front	Øxw (mm)	Ø 230×75
3.3	Tyre size,rear	Øxw (mm)	Ø 84×84
3.4	Additional wheels(dimensions)	Øxw (mm)	Ø 100×40
3.5	Wheels,number front/rear(x=driven wheels)		1x2/2/4
3.6	Tread,front	b10 (mm)	500
3.7	Tread,rear	b11 (mm)	367
Dimensions			
4.4	Lift	h3 (mm)	120
4.9	Height of tiller in drive position min./max.	h14 (mm)	946 / 1338
4.15	Height, lowered	h13 (mm)	85
4.19	Overall length	l1 (mm)	1762
4.20	Length to face of forks	l2 (mm)	612
4.21	Overall width	b1 (mm)	729
4.22	Fork dimensions	s/e/l (mm)	60 / 173 / 1150
4.25	Width across forks	b5 (mm)	540
4.32	Ground clearance, centre of wheelbase	m2 (mm)	25
4.34	Aisle width for pallets 800 x1200 lengthways	Ast (mm)	2250
4.35	Turning radius	Wa (mm)	1585
Performance data			
5.1	Travel speed,laden/unladen	km/h	6.0 / 6.0
5.2	Lift speed,laden/unladen	m/s	0.027 / 0.035
5.3	Lowering speed,laden/unladen	m/s	0.042 / 0.027
5.8	Max. gradeability, laden/unladen	%	6 / 10
5.10	Service brake		Eletromagnetic
Electric-engine			
6.1	Drive motor rating S2 60min	kW	1.3
6.2	Lift motor rating at S3 10%	kW	0.8
6.3	Battery acc. to DIN 43531/35/36A,B,C,norm		B,2Pzb
6.4	Battery voltage,nominal capacity K5	V / Ah	24 / 180
6.5	Battery Weight(+/-5%)	kg	215
6.6	Energy consumption acc. to VDI cycle	kWh/h	0.75
Additional data			
8.1	Type of drive control		AC speed Control
8.4	Sound level at driver's ear acc. to EN 12053	dB(A)	<70