

FPS12/FPS15 FPS16

Comprehensive Design of Mast Versions and Lift Capacities for Different Demands



INTRODUCTION

The FPS Series and FPS16 for medium stacking operations with capacities up to 1200kg/1500kg/1600kg.

The FPS16 with wide mast for high residual lift capacities and perfect view through the mast.

The optional foldable platform with sideways protective arms or the maintenance free batteries for low duty applications makes this truck the ideal assistant.

The powerful AC-drive technology and the CAN BUS tiller reduces maintenance and increase the overall performance.

ADVANTAGES:

- Powerful high quality AC drive unit.
- Optional FPS- Electric power steering system.
- 3PzS battery cells or maintenance free semi-traction batteries.
- The 1500kg version comes with a higher battery capacity for longer autonomous operations.
- Different mast versions available.
- Robust and ergonomic design with various storage areas.
- Optional foldable platform with protective arms.



Powerful high quality AC drive unit ensures high performance with low maintenance cost.

Optional FPS- Electric power steering system.

Ergonomic CAN-BUS tiller, for both left-handed and right handed operators.



High performance 3PzS (4PzS) DIN-standard battery cells for long operations.



Optional foldable platform with protective arms. The cushioned platform ensures safety in all traveling conditions.



Key-switch, emergency switch and battery discharge Indicator.



Diverse storage areas for stretch foils, documents or clipboards, etc.



Foldable platform allows higher flexibility in narrow spaces.

Several mast versions are available for fps-Series with different lifting heights.



FPS-series

MasttableFPS12/FPS15

Designation	Lowered mast height h_1 (mm)	Free lift height h_2 (mm)	Lift height h_3 (mm)	Lift+fork height h_3+h_{13} (mm)	Extended mast height h_4 (mm)
FPS12					
Two-stage mast	1976	1519	1519	1600	1976
Two-stage mast	1796	120	2519	2600	2996
	1946	120	2819	2900	3296
	2096	120	3119	3200	3596
	2296	120	3519	3600	3996
Two-stage mast FFL (Full-Free-Lift)	1946	1484	2819	2900	3281
	2096	1634	3119	3200	3581

FPS15					
Two-stage mast	1946	150	2819	2900	3281
Two-stage mast FFL (Full-Free-Lift)	1946	1484	2819	2900	3281
Three-stage mast	1726	—	3319	3400	3939
Three-stage mast FFL	1726	1120	3319	3400	3925
Three-stage mast	1796	—	3519	3600	4139
Three-stage mast FFL (Full-Free-FFL)	1796	1260	3519	3600	4125

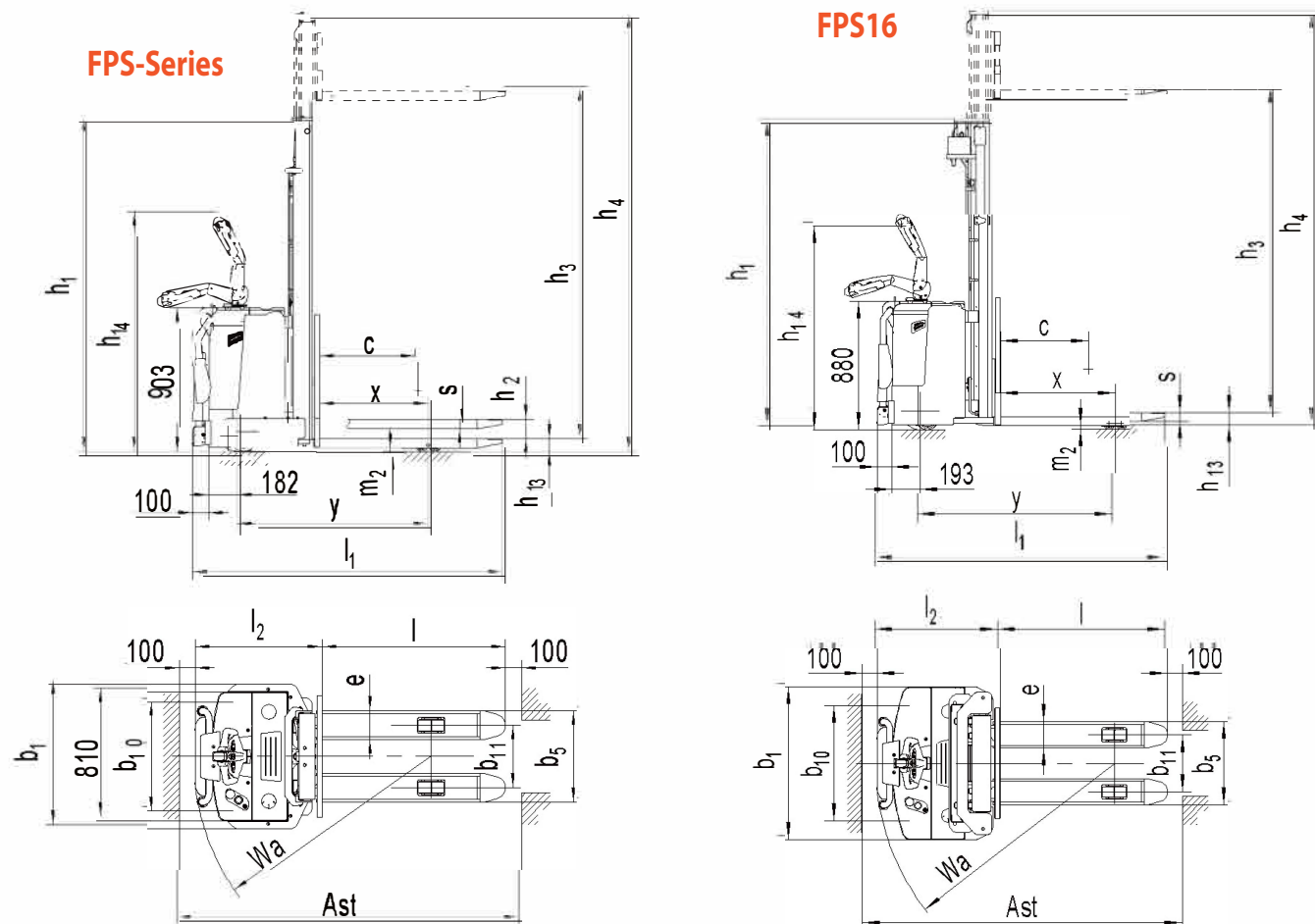

Type sheet for industrial truck acc. to VDI 2198 1KG=2.2LB 1INCH=25.4MM

Distinguishing mark	1.2	Manufacturer's type designation		FPS12	FPS15	FPS16
	1.3	Power (battery ,diesel, petrol, gas, manual)		Battery	Battery	Battery
	1.4	Operator type		Pedestrian	Pedestrian(stand)	Pedestrian(stand)
	1.5	Load Capacity / rated load	Q (t)	1.2	1.5	1.6
	1.6	Load centre distance	c (mm)	600		
	1.8	Load distance ,centre of drive axle to fork	x (mm)	684		784
Weight	1.9	Wheelbase	y (mm)	1196	1235	1336
	2.1	Service weight	kg	960	1035	1450
	2.2	Axle loading, laden front/rear	kg	830/1330	880/1655	1400/1650
Tires, chassis	2.3	Axle loading, unladen front/rear	kg	730/230	780/255	1130/320
	3.1	Tires		Polyurethane(PU)		Polyurethane(PU)
	3.2	Tire size,front	Φ xw (mm)	Φ 252x88		Φ 252x88
	3.3	Tire size,rear	Φ xw (mm)	Φ 80x70		Φ 80x70
	3.4	Additional wheels(dimensions)	Φ xw (mm)	Φ 150x54		Φ 150x54
	3.5	Wheels,number front/rear(x=driven wheels)		1x +2/4		1x +2/4
	3.6	Tread, front	b_{10} (mm)	686		790
Dimensions	3.7	Tread, rear	b_{11} (mm)	390/505		390/505
	4.2	Lowered mast height	h_1 (mm)	2096	1946	2102
	4.3	Free Lift height	h_2 (mm)	120	150	—
	4.4	Lift height	h_3 (mm)	3119 ³⁾	2819 ⁴⁾	4515
	4.5	Extended maximal height	h_4 (mm)	3596	3281	5112
	4.9	Height of tiller in drive position min./ max.	h_{14} (mm)	985/1420		961/1396
	4.15	Height, lowered	h_{13} (mm)	81		85
	4.19	Overall length	l_1 (mm)	1846/1946	1883/1983	1895/1995
	4.20	Length to face of forks	l_2 (mm)	695/795	733/833	746/846
	4.21	Overall width	b_1 (mm)		910	1050
	4.22	Fork dimensions	s/e/l (mm)	60/180/1150		60/180/1150
	4.25	Distance between fork-arms	b_5 (mm)	570/685		570/685
	4.32	Ground clearance, centre of wheelbase	m_2 (mm)	26	21	25
	4.33	Aisle width for pallets 1000X1200 crossways	Ast (mm)	2320/2420	2360/2460	2400/2500
	4.34	Aisle width for pallets 800X1200 lengthways	Ast (mm)	2215/2315	2250/2350	2350/2450
4.35	Turning radius	Wa (mm)	1400/1500	1440/1540	1550/1650	
Performance data	5.1	Travel speed, laden/ unladen	km/h	6.0/6.0		6.0/6.0
	5.2	Lift speed, laden/ unladen	m/s	0.105/0.15		0.10/0.16
	5.3	Lowering speed, laden/ unladen	m/s	0.13/0.11		0.095/0.12
	5.8	Max. gradeability, laden/ unladen	%	6/12		6/12
	5.10	Service brake		Electromagnetic		Electromagnetic
	Electric- engine	6.1	Drive motor rating S2 60min	kW	1.3	
6.2		Lift motor rating at S3 4.5%	kW	2.2	3.0	3.0
6.3		Battery acc. to DIN 43531/35/36 A, B, C, no		No,cells 3PZS		No,cells 4PZS
6.4		Battery voltage, nominal capacity K5	V / Ah	24/210		24/280
6.5		Battery weight +/-5%	kg	200		250
6.6		Energy consumption acc: to VDI cycle	kWh/h	2.5		2.6
Additional data	8.1	Type of drive control		AC-Speed Control		
	8.4	Sound level at driver's ear acc. to EN 12053	dB(A)	<70		

1) No platform available, no FPS available

2) optional 1519mm,2519mm

3) optional 1519mm,2519mm,2819mm,3519mm 4)optional 2819mm,3319mm with full lift(FFL)