



Material Handling

EDGE
EDGE



FSS12X-AL FSS12X-IL Series Straddle Stacker

Li-ion or AGM Powered 2600lbs/1200kg , Lift height: up to 142inch/3.6m.

FSS12X-AL/ FSS12X-IL Series

The EDGE Smart Design Pallet Stackers

NEW!

FSS12X AL

- 2600lbs/1200kg Capacity **AGM**

- Perfect for light-duty applications.
- Compact & light service weight
- High maneuverability
- Maintenance-free Lead-acid Battery
- Integrated on-board 12A charger
- Ideal for use on mezzanines

FSS12X IL

- 2600lbs/1200kg Capacity **Li-ion**

- Perfect for light-duty applications.
- Compact & light service weight
- High maneuverability
- Fast-charging Li-ion batteries.
- Integrated on-board 25A charger
- Ideal for use on mezzanines
- Ultimate solution for light duty operations



Smart and Ergonomic Tillers

Standard For FSS12X-AL and FSS12X-IL

BACK

FRONT

RFID card Access

RFID Card Access is optional for FSS12X-AL and standard for FSS12X-IL

RFID card provides faster access to equipment and ideal for applications when one truck needs to be used by different operators

Vertical Driving in Confined Space



The function of driving with tiller in the **vertical position** helps with work in confined area without sacrificing of safety.

The tiller bar is supported by the air spring which helps to return the tiller to its vertical position without strike in the end point.

For increase of operation comfort and safety the trucks are equipped with speed reduction function in turns.



Great stability and safety with its 3-point structure design

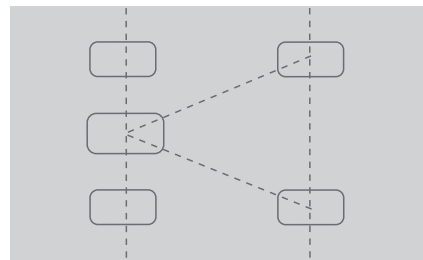
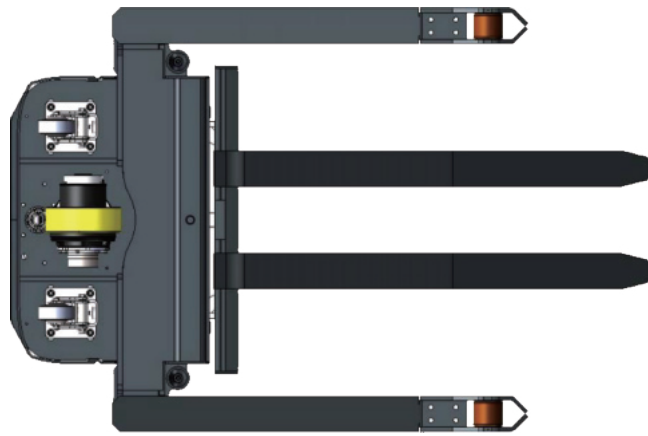

Chassis with 3+2-pointstructure: 1x+2/2

- The drive wheel located in the middle for better traction and stability of the stacker.
- The support wheels with suspension are located from left and right sides and provide better lateral stability to the truck.
- Support straddle legs are equipped with single rollers.

Maintenance Friendly

Convenient and fast access to any component of the truck, no elements are located in areas difficult to reach. No Special tools are required.



Robustness and Perfect Observation



Steel cover

The main cover is made out of steel with thickness 2.0mm



Tiller is made out of PA6 30% of glass fiber material, having high strength.

Capacity of 1200kg with high residual value at maximum height (load center distance 600 mm)

Real mast profiles are used for long life-time, no cheap bended solutions used. All directed to maintain performance of the truck during its life-cycle.

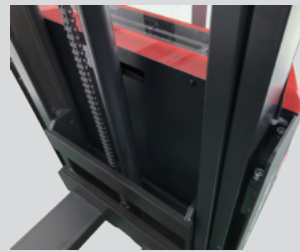

Support legs are made out of solid steel (not tube) to have enough rigidity to ensure the stability and safety.

The width of each leg is consistent which prevents possible hooking of pallets and racks when driving out from the racking system.

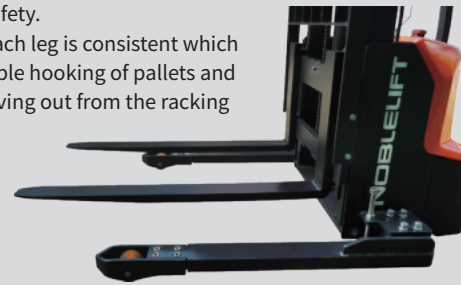

Wide mast provides perfect observation of forks, the field of view is clear and not interrupted by mast sections, cylinder or chains.



The operator can always clearly see the forks which significantly increases safety of operation.

Adjustment of support legs and forks



The support legs are fixed with screws located outside of the truck's body (4 screws for each side). The position can be easily adjusted according to the customer's needs to achieve the overall width of the truck: 46.5"/50.5"/54.5"/58.3".

Forged forks are used for long life-time, width of forks is adjustable 9.9-31.5" The truck is equipped with LBR (load back rest) as standard equipment.



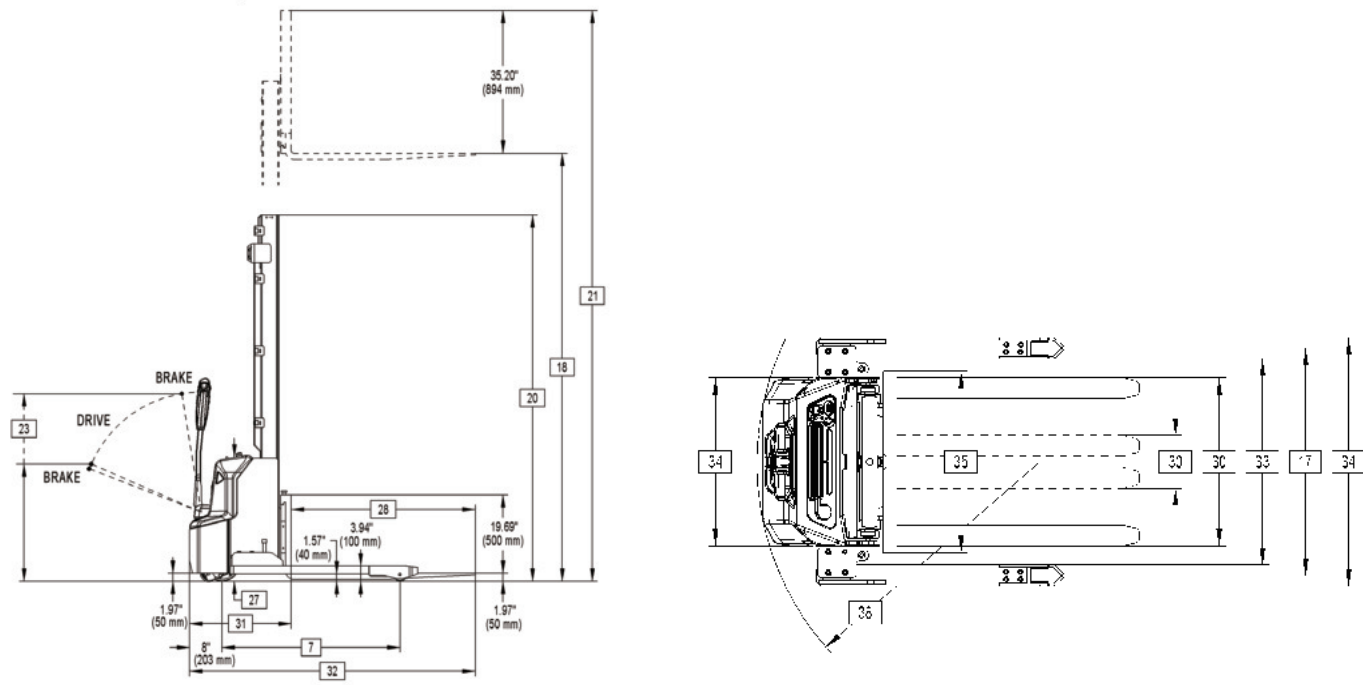

Mast table FSS26X-AL/FSS26X-IL							
Lift Height		in	63	79	102	126	142
Collapsed Height		in	76.38	92.13	70.47	76.38	82.28
Extended Height	w/o Load Backrest	in	82.68	98.43	122.05	133.86	145.67
	w/ Load Backrest	in	98.19	113.94	137.56	149.37	176.93

Mast table FSS12X-AL/FSS12X-IL							
Lift Height		mm	1600	2000	2600	2900	3200
Collapsed Height		mm	1940	2340	1790	1940	2090
Extended Height	w/o Load Backrest	mm	2100	2500	3100	3400	3700
	w/ Load Backrest	mm	2494	2894	3494	3794	4494



FSS12X AL
 2x12 85Ah (5Hr) AGM maintenance free batteries are used. Optionally available 2x12 106Ah (5Hr).



For FSS12X AL the charger with current 12A is used. The standard charging time is 7 hours.



FSS12X IL
 24V 60Ah Lithium LiFePO4 battery with BMS. Lithium battery has connection terminals with screws and located inside the steel case.



For FSS12X IL the charger with current 25A is used. The standard charging time is 2.5 hours. Opportunity charging is supported.

The **FSS12X AL** stacker is equipped with maintenance-free 24V/60Ah LiFePO4 type Li-ion battery with fast charging and ultra-high number of charging /discharging cycles during life time; opportunity charging feature basically does not limit your operation time. The integrated BMS provides the same features as the BMS for the batteries of pallet trucks(refer to pallet truck section). The on-board charger with 25A current can provide full charge for less than 2.5 hours with great efficiency.

The **FSS12X IL** stacker is equipped with 2x12V 85Ah VRLA-AGM maintenance free batteries. Optionally available 2x12V 106Ah batteries for longer operation. The stacker is equipped with 12A on-board charger. The charging time is 7-8 hours, opportunity charging is not available.



Type sheet for industrial truck acc. to VDI2198 (1KG=2.2LB 1INHG=25.4MM)

		Imperial						Metric							
General Information															
2	Model	FSS26X-AL/FSS26X-IL						FSS12X-AL/FSS12X-IL							
2	Mast Type	in	63	79	102	114	126	142	1600	2000	2600	2900	3200	3600	
3	Power	Electric													
4	Operator Type	Walkie													
5	Load Capacity	lb kg	2600						1200						
6	Load Center	in mm	24						600						
7	Wheelbase	in mm	43.74						1111						
8	Weight Less Battery	lb kg	1421	1466	1587	1609	1631	1675	645	665	720	730	740	760	
Tires															
13	Wheel Size Front (d x w)	in mm	8.27 x 2.76						210 x 70						
14	Wheel Size Rear (d x w)	in mm	3.31 x 2.76						84 x 70						
15	Additional Wheels Caster Wheel (d x w)	in mm	3.94 x 1.57						100 x 40						
16	Wheels Number (x = driven)	Front / Rear	1x + 2 / 2												
17	Track Width	in mm	Inside Straddle + 3.94						Inside Straddle + 100						
Dimensions															
18	Lift Height	in mm	63	79	102	114	126	142	1600	2000	2600	2900	3200	3600	
20	Collapsed Height	in mm	76.38	92.13	70.47	76.38	82.28	90.16	1940	2340	1790	1940	2090	2290	
21	Extended Height	w/o Load Backrest	in mm	82.68	98.43	122.05	133.86	145.67	161.42	2100	2500	3100	3400	3700	
		w/ Load Backrest	in mm	98.19	113.94	137.56	149.37	161.18	176.93	2494	2894	3494	3794	4094	
23	Tiller Arm Height in Drive Position	in mm	27.95 / 45.28						710 / 1150						
24	Outrigger Height	in mm	3.94						100						
25	Lowered Fork Height	in mm	1.97						50						
27	Power Unit Height	in mm	29.92						760						
28	Fork Lengths	in mm	45.28						1150						
29	Fork Dimensions	Thickness x Width	1.57 x 3.94						40 x 100						
30	Width Across Forks	in mm	9.92 - 31.50						252 - 800						
31	Headlength	in mm	25.2						640						
32	Overall Length	in mm	Headlength + Fork Length												
33	Inside Straddle	in mm	38.62 / 42.56 / 46.50 / 50.43						981 / 1081 / 1181 / 1281						
34	Overall Width	Front	in mm	31.5						800					
		Rear	in mm	Inside Straddle + 7.87						Inside Straddle + 200					
35	Fork Carriage Width	in mm	33.27						845						
36	Ground Clearance	w/ Load below Mast	in mm	1.57						40					
37	Center Wheelbase	in mm	1.57						40						
38	Turning Radius	in mm	52.95						1345						
39	Length w/ Outriggers	in mm	56.14						1426						
Performance															
40	Travel Speed	w/ wo Load	mph km/h	2.61 / 2.80						4.2 / 4.5					
41	Lift Speed	w/ wo Load	fpm/m/s	21.65 / 31.50						0.11 / 0.16					
42	Lowering Speed	w/ wo Load	fpm/m/s	25.59 / 21.65						0.13 / 0.11					
44	Max Gradeability	w/ wo Load	%	4 / 10											
45	Service Brake	electromagnetic													
Battery															
47	Battery Voltage	2x12V Maintenance Free (PSE12BSL)	V / Ah	24 / 85											
		2x12V Maintenance Free (PSE12BSL,Option)	V / Ah	24 / 106											
		24V Lithium battery (PSE12NSL)	V / Ah	24 / 60											
48	Type of Controller	DC speed Control													
		2x12V Maintenance Free (PSE12BSL)	lb kg	119						54					
		2x12V Maintenance Free (PSE12BSL,Option)	lb kg	150						68					
49	Battery Weight	24V Lithium battery (PSE12NSL)	lb kg	42						19					

Note: English conversions are approximations. Metric conversions should be done to find true values.